

# **Harmonized Labor Status Concepts and Measures for the Analysis of Social Structures: A questionnaire module for comparative social surveys**

Jürgen H.P. Hoffmeyer-Zlotnik<sup>1</sup>  
and  
Uwe Warner<sup>2</sup>

<sup>1</sup>[juergen.hoffmeyer-zlotnik@sowi.uni-giessen.de](mailto:juergen.hoffmeyer-zlotnik@sowi.uni-giessen.de)

<sup>2</sup>[uwe,warner@orange.lu](mailto:uwe,warner@orange.lu)

# Structure of the paper

- Introduction and problems
- Measurements
  - a) in official statistics International Labour Organization  
Concept
  - b) in social research, questionnaire module
- Conclusion

# Standardized and harmonized indicators and measures

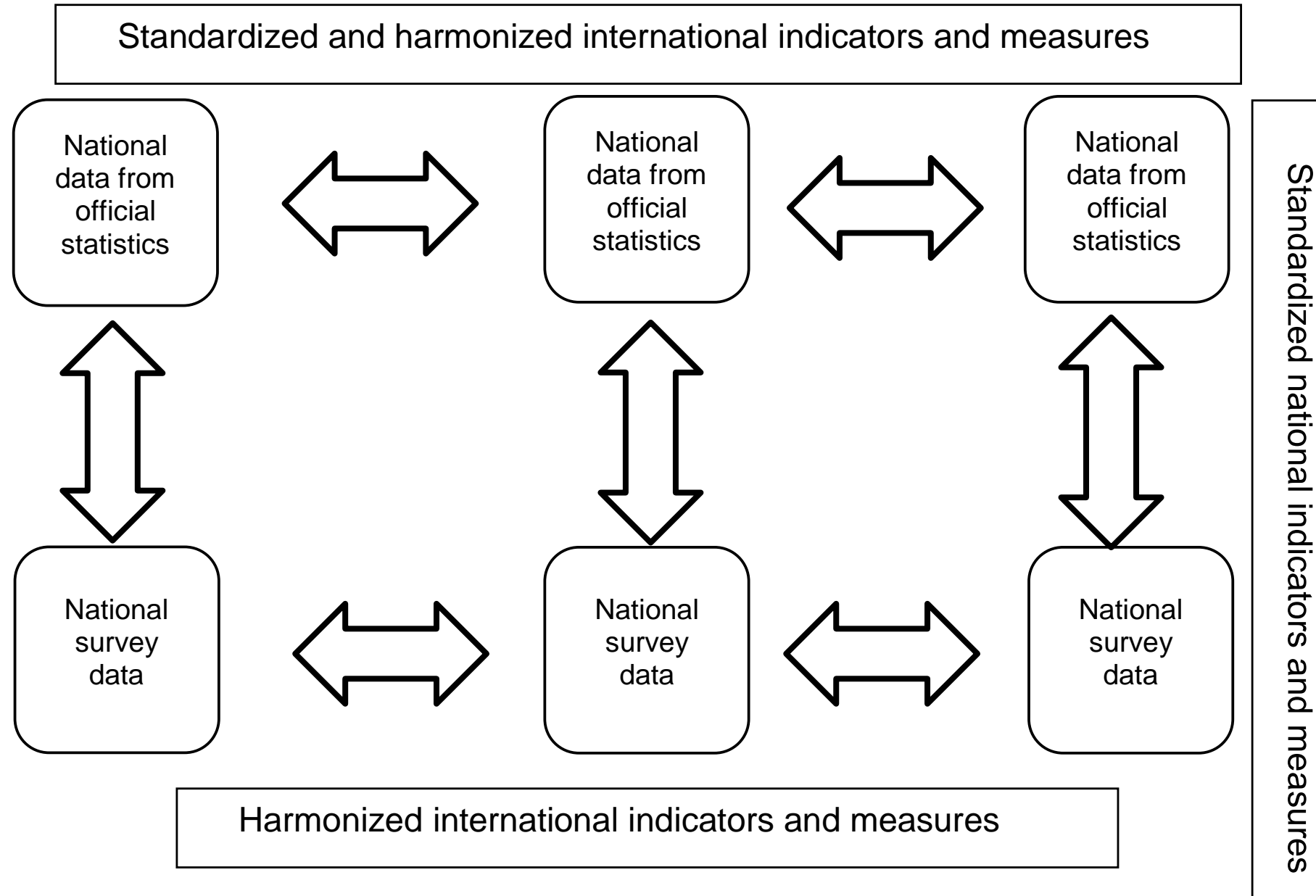

# Measures in official statistics

- **ILO Labor Force Concept of “economically active population”**

“... comprises all persons of either sex who furnish the supply of labour for the production of economic goods and services as defined by the United Nations systems of national accounts and balances during a specified time-reference period. ... includes all production and processing of primary products whether for the market for barter or for own consumption, the production of all other goods and services for the market and, ... , the corresponding production for own consumption.”

# Labor Force Concept of “economically active population”

currently active population		not currently active population
<p>employed</p> <ul style="list-style-type: none"> <li>- persons in specified age</li> <li>- self employed</li> <li>- members of armed forces</li> <li>- unpaid family workers</li> <li>- apprentices</li> </ul>	<p>unemployed</p> <ul style="list-style-type: none"> <li>- persons in specified age</li> <li>- without work</li> <li>- not self employed</li> <li>- currently available for work</li> <li>- seeking for work</li> </ul>	<ul style="list-style-type: none"> <li>- persons outside the specified age range</li> <li>- persons without work</li> <li>- not available for work</li> <li>- not seeking for work</li> </ul>
employed	not employed	

# ILO working status

## **Working status (as defined by the International Labour Organisation and EU regulation)**

1	Employed,
2	Unemployed,
3	Inactive
4	Compulsory military service
9	Persons less than 15 years old

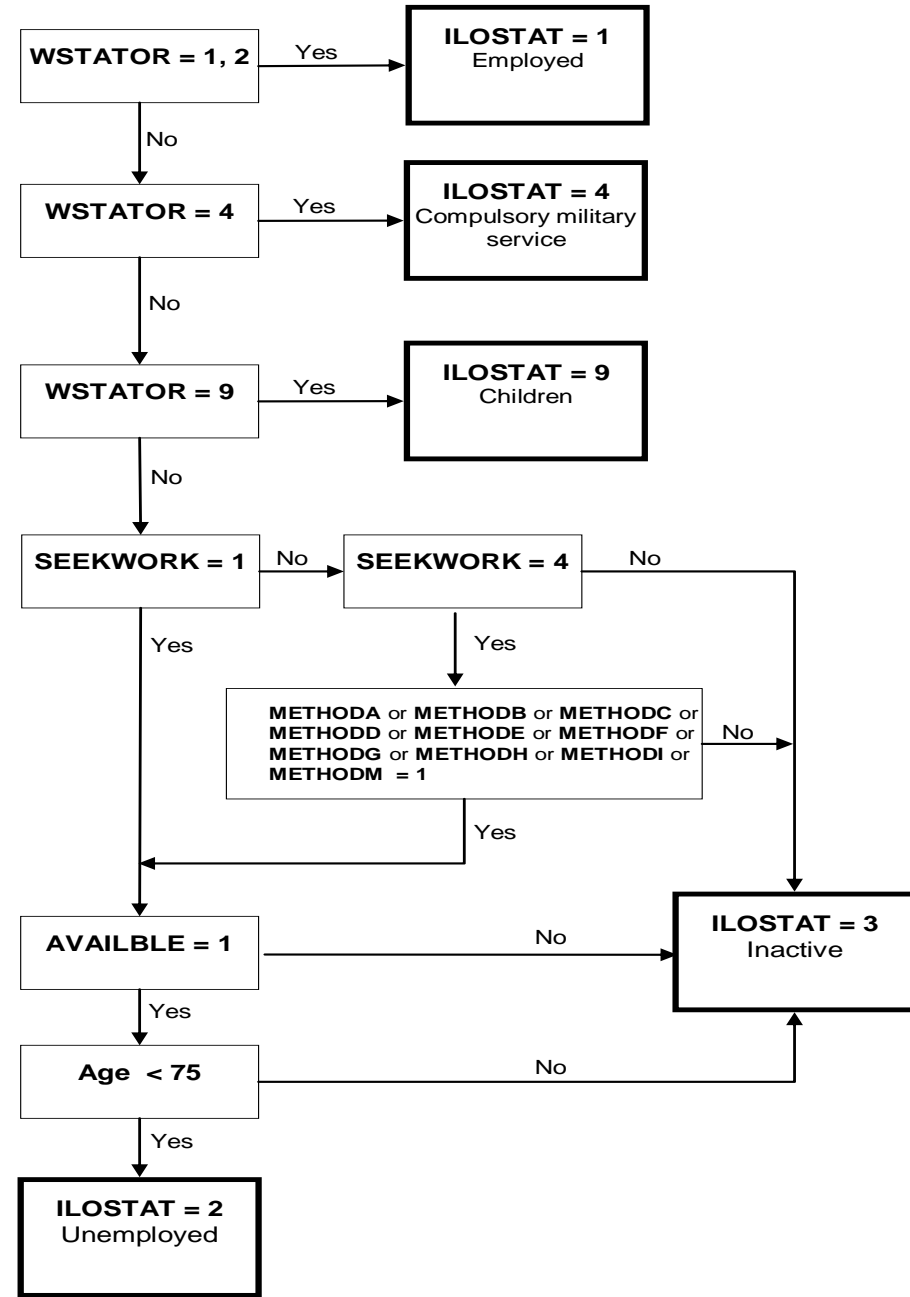

## ESS round 7

### F17a CARD 63

Using this card, which of these descriptions applies to what you have been doing for the last 7 days? Select all that apply.

PROMPT Which others?

CODE ALL THAT APPLY

- |   |    |
|---|----|
| in <u>paid work</u> (or away temporarily) (employee, self-employed, working for your family business) | 01 |
| in <u>education</u> , (not paid for by employer) even if on vacation                                  | 02 |
| <u>unemployed</u> and actively looking for a job  | 03 |
| <u>unemployed</u> , wanting a job but not actively looking for a job                                  | 04 |
| permanently <u>sick or disabled</u>   | 05 |
| retired   | 06 |
| in <u>community or military service</u> *   | 07 |
| doing <u>housework, looking after children or other persons</u>                                       | 08 |
| (other)   | 09 |
| (Don't know)  | 88 |



ASK IF MORE THAN ONE CODED IN F17b (code 1)

**F17c STILL CARD 63**

And which of these descriptions best describes your situation (in the last seven days)? Please select only one.

CODE ONE ANSWER ONLY

## F18

Can I just check, did you do any paid work of an hour or more in the last seven days?

Yes	1	GO TO F21
No	2	ASK F19
(Don't know)	8	

# Structures of ISCO 88 and ISCO 08 compared

Major groups		Sub-major groups		Sub-groups		Unit groups	
1	Managers, senior officials and legislators	3	4	8	11	33	28
2	Professionals	4	6	18	24	55	89
3	Technicians and associate professionals	4	5	21	20	73	86
4	clerks	2	2	7	9	23	28
5	Service and sales workers	2	2	9	12	23	40
6	Skilled agricultural, fishery, and forestry workers	2	2	6	6	17	18
7	Craft and related trades workers	4	5	16	16	70	66
8	Plant and machine operators and assemblers	3	3	20	13	70	42
9	Elementary occupations	3	6	10	11	25	33
0	Armed forces occupations	1	3	1	3	1	3
	<b>ISCO-88 total</b>	<b>28</b>		<b>116</b>		<b>390</b>	
	<b>ISCO-08 total</b>		<b>38</b>		<b>125</b>		<b>433</b>

# Our proposed harmonized module Labor Status for comparative analysis of social structures

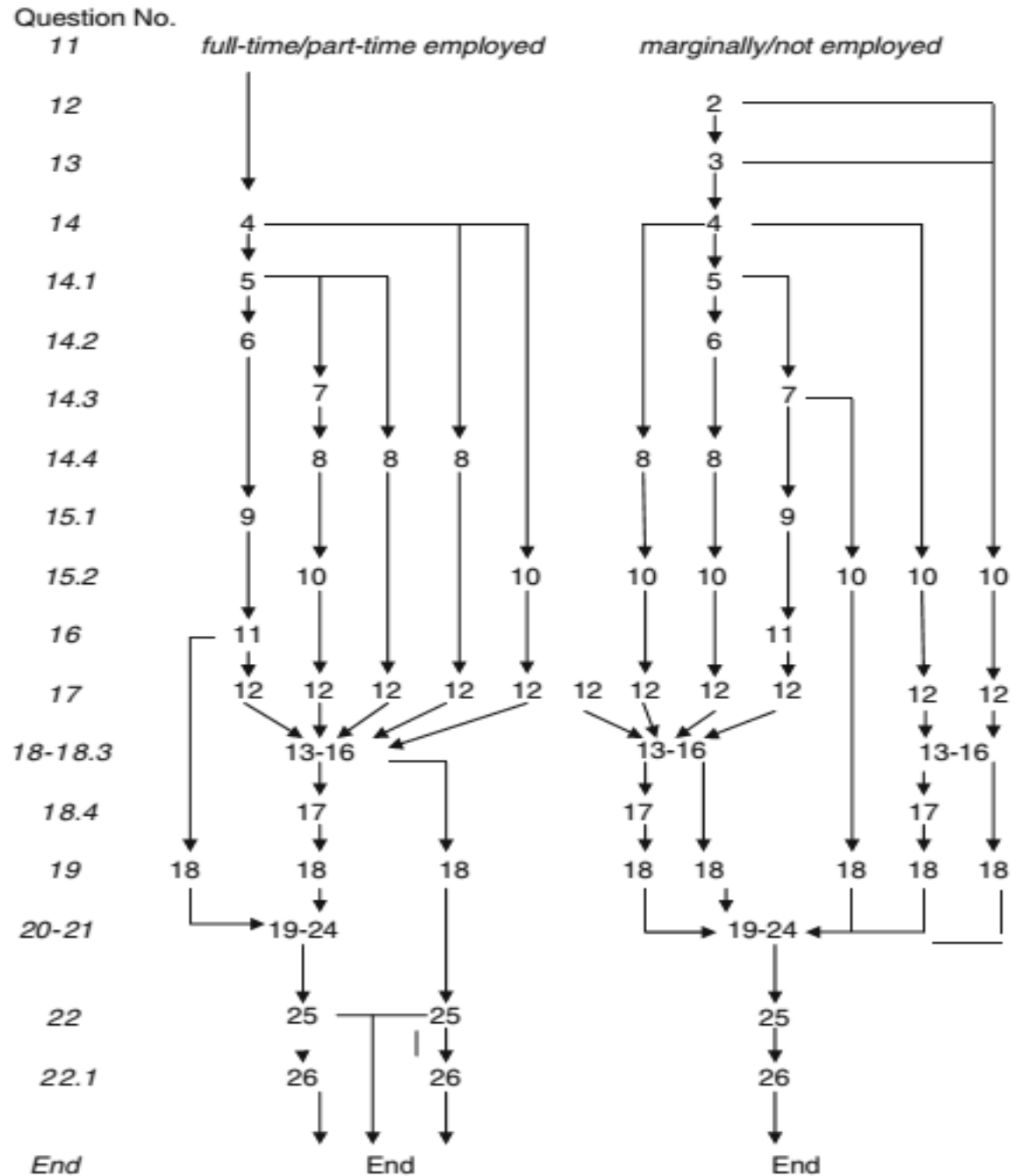

**11.** Are you currently ...

- 1 employed full time with a weekly working time of 35 hours or more
  - 2 employed part time with a weekly working time of 17 to 34 hours
  - 3 employed part time or on an hourly basis with a weekly working time of less than 17 hours or
  - 4 not employed
- 97 refused / 98 don't know

*INTERVIEWER: 'Employed' refers to work for pay (wage, salary, fee), profit (in the case of self-employed persons), or family gain (in the case of contributing family workers)*

*Filter:*

*if code 1 or 2 go to question 14*

*if code 3 or 4 go to question 12*

*if code 97 or 98 go to question 22*

In question 12, unemployed and part time employed people report their current situation on the labor market

In question 13, we asked unemployed, if they can start work on an offered job within two weeks

Question 14 reports the status on the labor market for part time employed respondents, the volume, the number of jobs and the homogeneity of job activities

Question 15, all employed give the volume of their occupational activities

Question 16, not (or not longer) employed decide between full or part time former occupation

Question 17 codes the ISCO for all respondent actually or formerly occupational active.

Question 18 surveys for various groups the information necessary to detect the job autonomy

Questions 19 to 21 are asked if the contacted respondent is not the main income earner of the household; the ISCO code and the job autonomy are surveyed

Question 22 collects information necessary to identify the ILO concept of the economically active population and its working status



*To all respondents*

*Only if question 19 = code 2 (transitional phrase):*

Now let's talk about you again.

**22.** Did you do any work for pay, profit or family gain for at least one hour during the last week (as an employee, a self-employed person, or as a contributing family worker)?

- 1 yes
- 2 no
- 97 refused
- 98 don't know

*Filter:*

*if code 1 or 97 or 98 go to question 23*

*if code 2 go to question 22.1*

**22.1** What is the main reason why you didn't work (at all) last week?

INTERVIEWER: Assign spontaneous response to a category – if necessary read out the categories.

- 01 short time working for technical or economic reasons
- 02 labour dispute, strike
- 03 school or vocational education, or further training
- 04 sickness, accident or temporary incapacity to work
- 05 maternity leave
- 06 parental leave
- 07 vacation
- 08 compensatory leave (in lieu of overtime pay or within the framework of a working time account)
- 09 personal or family reasons, child care, caring for household members or family members, sabbatical
- 10 bad weather
- 11 other reasons
- 97 refused / 98 don't know

# Conclusion

- The ILO concept is developed to detect the productivity of a national economy. Therefore all, even marginal employed people are included.
- A sociological concept has to separate respondents with an extent of work that defines social status and the derived prestige. This means that marginal employed and not working interviewees are filtered out, because their status and prestige are not determined by the labor force activity.
- The ILO concept is meaningless in social structure analysis, even if we gain the comparability with official statistics like the national accounts as references.

## Conclusion -2-

- Our proposed module uses 9 questions for full-time and part-time employed survey participants and 8 questions for marginal and not employed respondents. The survey burden is limited to a minimum of questions.
- The three questions about the occupational activity coded with ISCO allow the link to SIOPS, ISEI and EGP.

Thank you very much  
for your attention

juergen.hoffmeyer-zlotnik  
@sowi.uni-giessen.de

uwe.warner@orange.lu

Jürgen H.P. Hoffmeyer-Zlotnik  
Uwe Warner

Harmonising  
Demographic and  
Socio-Economic  
Variables for  
Cross-National  
Comparative  
Survey Research

 Springer

If you want  
please, download our entire labor status module  
from

<https://www.mydrive.ch/login>

Username: RC33@UweWarner

Password: LaborStatus